



# Leading Signaling Devices



Louder &  
Brighter  
since 1910.

**Auer Signal**



NEW PRODUCT LAUNCH



# Smart Signaling 50

New product family rolling  
out throughout 2025



The redefinition of  
industrial signaling



M22 panel mount Smart Signaling Family /  
Electronic modularity – multicolor & multifunction  
capabilities / Superior signaling performance compared  
to competitors / Innovative built-in features: Smart Control,  
Smart Diagnostics & System Protection / 3 Feature Lines:  
Basic, Standard & IO-Link / 3 Design Lines: Black,  
White & Stainless Steel

Series  
**SD50**  
Smart Dot

Series  
**SI50**  
Smart Indicator

Series  
**ST50**  
Smart Tower

**3** Series  
SD50  
SI50  
ST50

**3** Feature Lines  
Basic  
Standard  
IO-Link

**3** Design Lines  
Black  
White  
Stainless Steel

=

Endless Applications

Each series is available in three design lines



Black



White



Stainless Steel

## Signaling with a human touch



Capacitive touch buttons replace traditional mechanical buttons, providing seamless integration with optical signaling functions for enhanced performance and user interaction.

### THE SMART TOUCH BUTTON

In addition to the other Smart Dot 50 models — ranging from Basic version with one, two, or three colors, to a 50mm buzzer, and an advanced IO-Link variant — the Smart Dot 50 Series also includes a touch sensing functionality.

These motion- and wear-free touch buttons are engineered for reliable, long-lasting performance, even in harsh environments.

## Beacon or mini-tower?

The signaling area of our Smart Indicator exceeds the size of a single tower light module, while maintaining a more compact overall footprint. The lens design prevents false signaling caused by external light sources, ensuring reliable operation. Additionally, our Smart Signaling 50 series delivers industry-leading color fidelity and saturation, with precise color consistency — red remains vivid red, and green stays true green under all conditions.

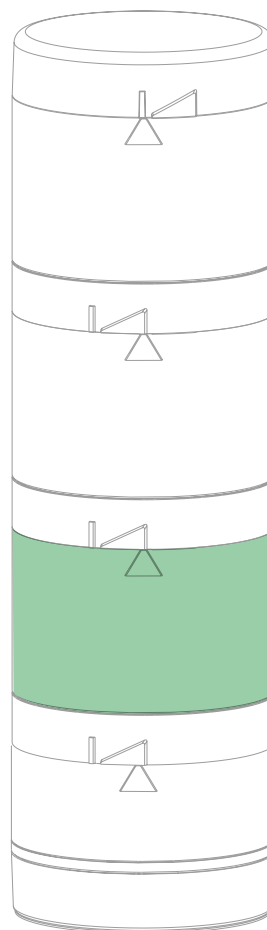

70mm

Our Smart Indicator is both in one device



50mm

## Immediate Installation

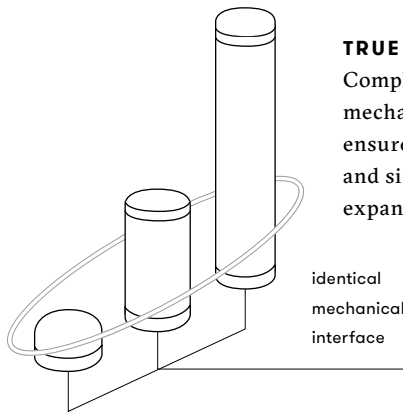

**TRUE PLUG AND PLAY**  
Complete electronic and mechanical compatibility ensures effortless upgrades and simplifies system expansion

identical  
mechanical  
interface



Simplified installation  
thanks to M22 threaded  
mount and M12 pin plug

- no drilling template
- minimum training required

## Superior performance compared to competing products

Auer Signal's Basic line of the Smart Dot 50 is 4x brighter than comparable products. Reference values are based on test conditions using green light at 24V DC, with thermal stabilization at room temperature.

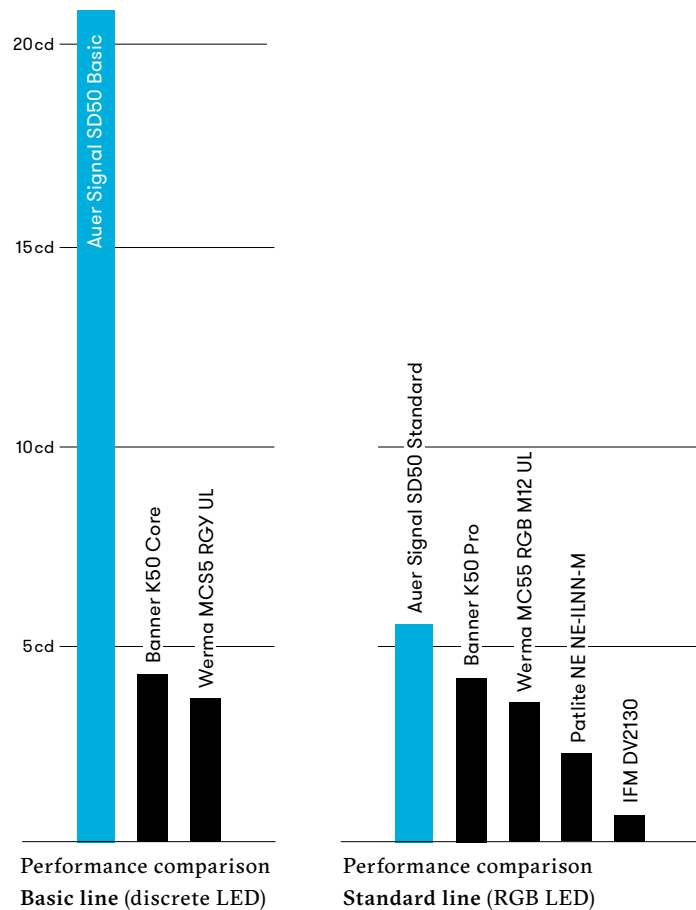

## Smart Control

Unique in  
the Signaling  
Market

Device configuration is moved from the signaling device to the controller, offering IO-Link-level functionality during operation — without extra cost and easily retrofittable to conventional control systems.

## Smart Diagnostics

The system performs a hardware check simultaneously without any signaling delay. If critical errors are detected, a subtle diagnostic visualization is displayed.

Device-related errors can be quickly detected without the need for additional measuring equipment

## Smart Protection



### SYSTEM OVERLOAD PROTECTION

The controller's power load is reduced by actively controlling and limiting inrush current.



### ACTIVE THERMAL MANAGEMENT

Smart Signaling devices operate at peak efficiency with active temperature control, optimizing LED lifespan even in the harshest conditions.



### HIGH LEAKAGE CURRENT RESISTANCE

For robust and error-free use in the industrial sector.



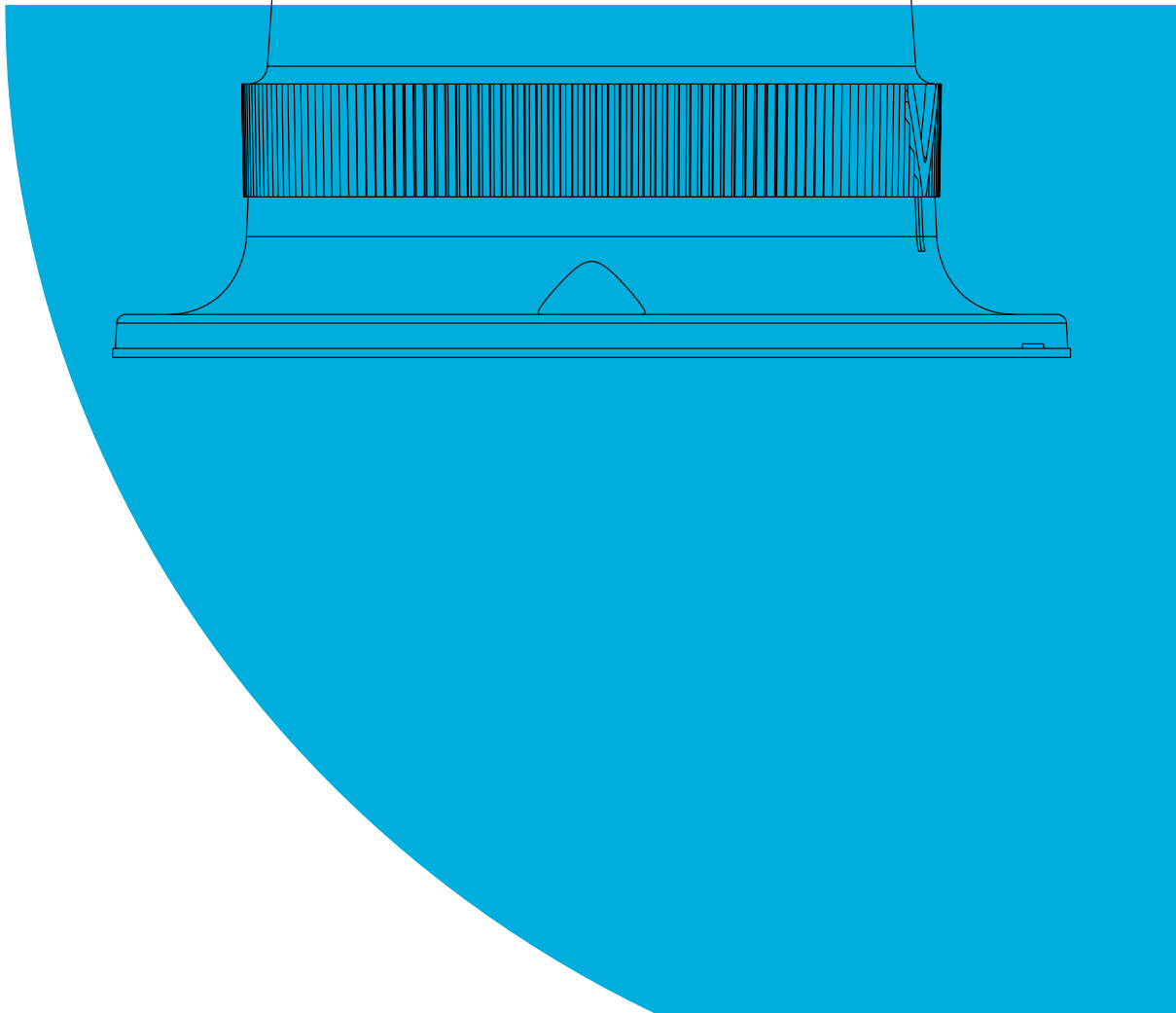
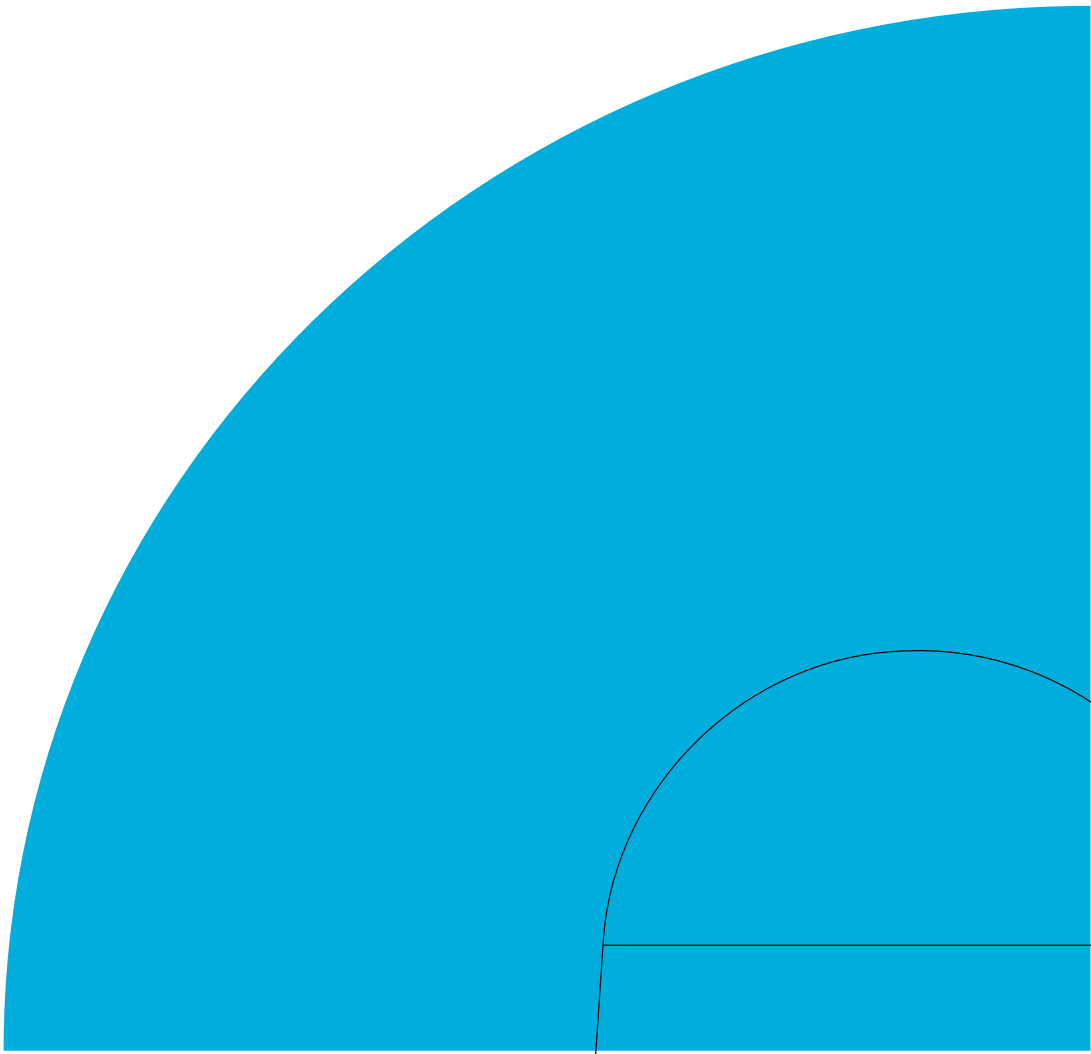



# Visual signaling devices

- s. 10 Series R
- s. 12 Series R compact
- s. 14 Series Q
- s. 16 Series M22



The brightest industrial LED beacon available in 3 performance classes and 2 design options



## Series R

The LED-Design-Powerhouse

The highest-performance industrial LED beacon, specifically engineered for applications in direct sunlight. Its streamlined series design offers an impressive range of versatile functions.





#### CUSTOMER BENEFITS

- high-performance industrial LED signal beacon for applications in direct sunlight
- maximum peripheral visibility for clear, unmistakable signaling
- highest visibility power in a sleek, compact design

#### COMMON APPLICATIONS

- long-range signaling for outdoor environments
- mobile heavy machinery such as cranes and earth moving equipment
- power plants
- warning systems for large industrial facilities
- bridges and toll booths

#### KEY FEATURES

- brightest LED beacon <150mm
- all in one functionality
- very bright and homogeneous peripheral signaling
- 7 functions plus 5 stages
- high ingress protection ratings: IP66, UL Types 4/4X/13

#### CONTROL

- conventional (via input terminal)



Audible base  
for Series R

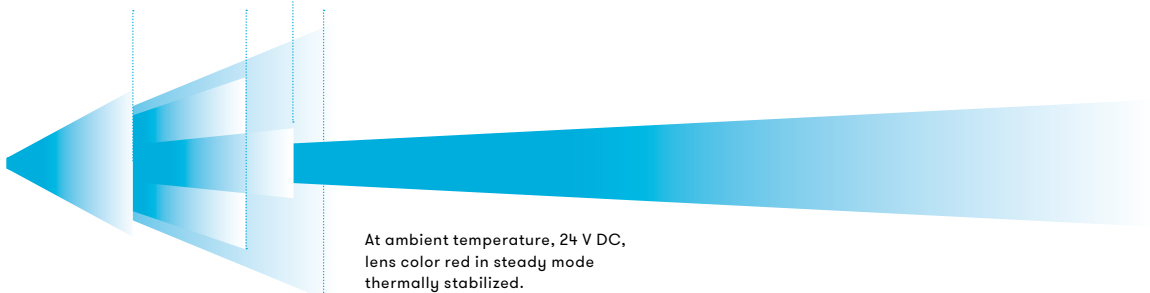
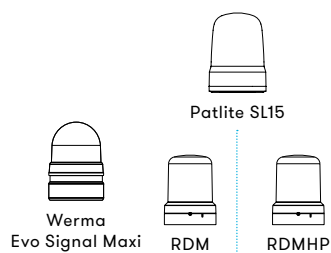

With the introduction of the RDM Ultra Performance, we complete the success of the R Series beacons with its most advanced model yet. Offering brightness 2 to 4 times greater than any other beacon on the signaling market, the RDMUP is designed to compete even with direct sunlight.

# Series R compact

The compact LED-  
Design-Powerhouse

For high aesthetic  
demands and  
functionality



The milky white lens of the compact R Series provides a beautiful, homogeneous light pattern. The minimalistic design lets the RCMM completely disappear when it's not activated.

**CUSTOMER BENEFITS**

- the ideal solution for indoor applications requiring high aesthetic standards
- elegant, uniform light distribution achieved through a milky-white lens and advanced LED technology

**COMMON APPLICATIONS**

- public spaces with architectural requirements, such as museums, theaters, residential buildings, and offices
- office-like production environments
- pharmaceutical and laboratory industries
- customer flow management systems
- replacement for signal towers or traffic lights in commercial and light industrial settings

**KEY FEATURES**

- ultra-bright RGB multifunction beacon
- brilliant and uniform 360° omni-directional signaling
- offers 7 functions with 4 stages

**CONTROL**

- conventional (via input terminal)



---

**RCMM**  
Multicolor with multiple functions



---

**RCDM**  
Multifunctional beacon



# Series Q

the Bright

Square design  
in 3 sizes



Our Series Q is the most versatile signaling beacon, available in three sizes with a square design. The models allow for flexible combinations of different beacon colors or integration with electronic horns in the same size format.

**CUSTOMER BENEFITS**

- excellent lateral and frontal illumination
- can be easily combined to a traffic light solution
- audible combinations with Series A models
- particularly well-suited for wide-area outdoor signaling, such as large building premises, industrial facilities, and harbors

**COMMON APPLICATIONS**

- traffic light systems
- signaling for heavy machinery
- installations in industrial buildings
- crane and container technology applications
- industrial marker lights

**KEY FEATURES**

- bright, square beacon available in multiple sizes

**CONTROL**

- conventional (via input terminal)

The brightest M22 panel  
mount beacon series



## Series M22

the Brightest  
Installable





The versatile M22 panel mount series is available in three sizes: Ø 30 mm, Ø 45 mm, and Ø 65 mm. Its high luminosity and signaling effect are visible both frontally and laterally thanks to the dome-shaped design. The beacon is exceptionally durable and vibration-resistant, with a high ingress protection rating of IP65 (UL Type 4/4X) and IP67 (UL Type 6) for pre-wired models.



#### CUSTOMER BENEFITS

- brightest M22 panel mount beacon series
- clear and unmistakable signaling effect, outshining other components on control cabinets and panels
- space-saving connection technology for confined areas
- extensive portfolio of colors, functions, and voltage options



#### COMMON APPLICATIONS

- bright addition to limited switch cabinet lighting
- ideal for off-road special vehicles
- marker or warning lights and indicators for forklifts and AGVs
- signaling for heavy machinery

#### KEY FEATURES

- robust, bright M22 panel mount beacon
- ideal for on-machine installation due to high ingress protection ratings: IP66, UL Types 4/4X/13 and vibration resistance

#### CONTROL

- conventional (via input terminal)

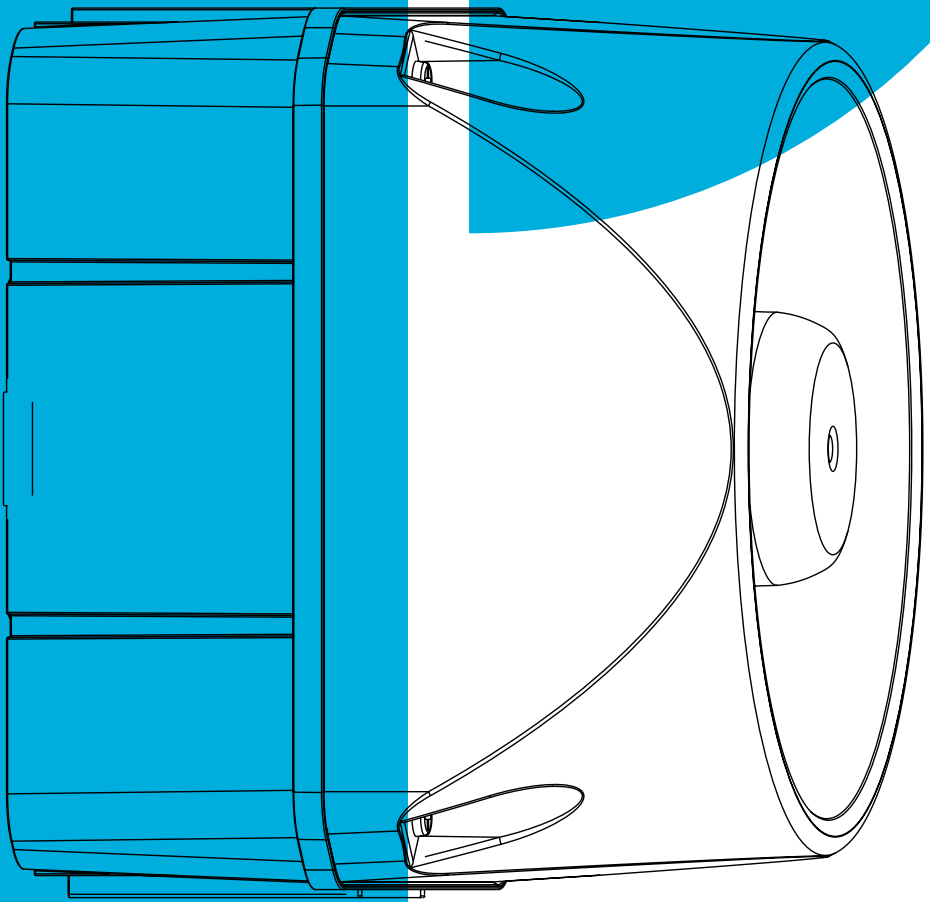

# Audible signaling devices

s. 20 Series A

s. 22 Series M22

# Series A

the Mighty

Square design  
in 3 sizes



Series A is the largest and most versatile multi-tone sounder, available in three square design sizes: 94 mm, 132 mm, and 184 mm. All Series A sounders feature a high protection rating (IP66, UL Types 4/4X/13) and exceptional impact resistance (IK09), making them highly durable and vandal-proof.

**CUSTOMER BENEFITS**

- clear audible warning signals, even in noisy environments such as process engineering or marine industry
- distinct sound options for various situations, with external stage control
- compatible with visual combinations using Series Q beacons

**COMMON APPLICATIONS**

- warning system
- heavy machine signaling
- industrial building installations
- crane & container technology
- ideal for broad-area outdoor applications, including large building premises, industrial facilities, and harbors

**KEY FEATURES**

- loud square sounder in different sizes
- ingress protection ratings: IP66, UL Types 4/4X/13 and vibration resistance

**CONTROL**

- conventional (via input terminal)



The loud M22  
panel mount  
buzzer in 3 sizes



## Series M22

the Loudest  
Installable

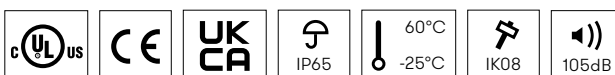



The versatile M22 panel mount sounder series is available in three sizes:  $\varnothing$  30 mm,  $\varnothing$  45 mm, and  $\varnothing$  65 mm. It delivers a powerful signaling effect with a sound output of up to 105 dB.

**CUSTOMER BENEFITS**

- high-volume output ideal for areas with machinery and ambient noise
- easy integration into control cabinets and panels with standard M22 mounting hole
- space-efficient connection technology using screw or plug-in terminals

**COMMON APPLICATIONS**

- loud enhancement for limited switch cabinet sounders
- off-road special vehicles
- warning sounder for forklifts & AGVs
- machine status warning

**KEY FEATURES**

- industrial grade panel mount sounder
- ideal for on-machine installation due to high ingress protection ratings: IP65, UL Types 4/4X/13 and vibration resistance

**CONTROL**

- conventional (via input terminal)



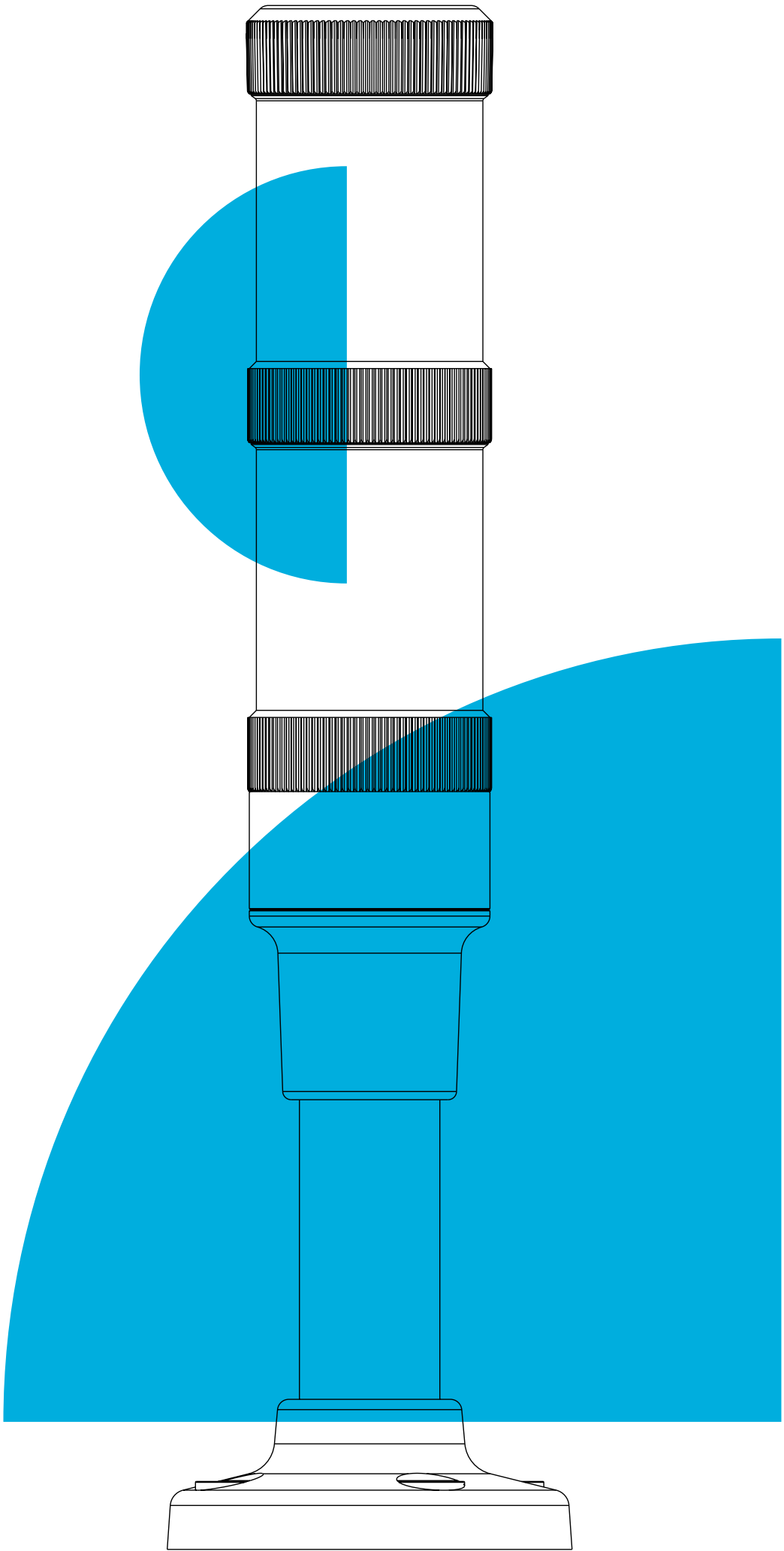



# Stack lights

s. 26 MT60

s. 28 PC7

s. 30 CT5

s. 32 ECO

s. 34 HD

Modular	40 mm Ø	50 mm Ø	60 mm Ø	70 mm Ø
PC7				✓
CT5		✓		
ECO	✓		✓	✓

Pre-configured	30 mm Ø	60 mm Ø	Semi-circular Design, 90 mm Ø
MT60		✓	
HD			✓

# MT60

Monolithic  
Simplicity

Compact stack light, perfect for laboratories, hygiene-sensitive environments, and the pharmaceutical industry

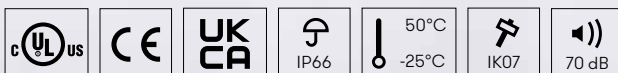



The signal tower designed to meet high aesthetic standards and strict hygiene requirements. Its smooth surface allows for easy cleaning.

#### **CUSTOMER BENEFITS**

- compact design blends into modern industrial and building environments
- easy to clean thanks to monolithic design (minimal joints)
- clear lens ensures no loss of performance or false signaling

#### **COMMON APPLICATIONS**

- ideal for laboratories, printers and office applications
- machines in production plants with high aesthetic requirements
- customer flow management systems
- optimized for smart buildings applications
- pharmaceutical industry

#### **KEY FEATURES**

- fixed color positions: green, yellow, red
- escalation options with flashing red and/or sound alerts
- bright, uniform circular signaling
- compatible with all common mounting types

#### **CONTROL**

- conventional (via push-in terminal or M12)



The tallest  
stack light up to  
7 modules

## PC7

Nothing but perfect

Up to 6 times brighter than comparable signal towers.  
Maximum flexibility with up to 7 positions. Innovative  
MP3/recordable voice sound module available.



**CUSTOMER BENEFITS**

- future-proof, modular signal tower with maximum flexibility, supporting up to 7 modules
- even brighter top light module with omni-directional light distribution
- built to withstand harsh environments with UV-stabilized polycarbonate, a bonded tube base, and compact electronics
- seamless integration with IO-Link technology

**COMMON APPLICATIONS**

- machine status indication (e.g. running, stopped, or fault) in industrial environments
- production line monitoring (indicating the status of various stages in a production line, helping operators manage workflow and efficiency)
- warning and alert systems (e.g. signal safety alerts, malfunctions, or emergency situations) in factories or warehouses
- process control and automation (e.g. to provide real-time feedback on system performance, helping monitor processes and identify issues)

**KEY FEATURES**

- up to 7 modules/inputs providing maximum flexibility
- brightest and most uniform circular signaling in a 70mm stack light
- extremely robust design meets toughest ingress ratings (IP66/67, UL Types 4/4X/13)
- supports all standard illumination functions including steady and flashing, and also special functions including rotating, multi-color, and multi-functional
- mounting flexibility with broad range of bases and accessories

**CONTROL**

- conventional (via push-in terminal or M12)
- IO-Link (via push-in terminal or M12)





Cost-optimised modular  
50mm stack light

# CT5

## Competitive Simplicity



The cost-optimised 50mm signal tower is the right choice for a wide range of 24V DC applications.



#### CUSTOMER BENEFITS

- cost-optimised modular stack light for standard applications
- designed for modern industrial environments
- meets higher functional requirements beyond the MT60
- available with white bases

#### COMMON APPLICATIONS

- machine status indication (e.g. running, stopped, or fault) in industrial environments
- production line monitoring (indicating the status of various stages in a production line, helping operators manage workflow and efficiency)
- warning and alert systems (e.g. signal safety alerts, malfunctions, or emergency situations) in factories or warehouses
- process control and automation (e.g. to provide real-time feedback on system performance, helping monitor processes and identify issues)

#### KEY FEATURES

- up to 5 modules / inputs
- bright and homogeneous circular signaling
- all standard functions available

#### CONTROL

- conventional (via push-in terminal or M12)
- IO-Link (via push-in terminal or M12)



# Eco

the Flexible Allrounder





The versatile all-rounder among modular signal towers, available in three sizes: 40mm, 60mm, and 70mm. For maximum signaling impact, also available with High Power LEDs.

Modular signal tower series offering an outstanding price-performance ratio



ECO 40

ECO 60

ECO 70

#### CUSTOMER BENEFITS

- classic, modular signal tower with extensive portfolio
- flexibility in the choice of light sources, as the light source is not permanently bonded to all modules

#### COMMON APPLICATIONS

- machine status indication (e.g. running, stopped, or fault) in industrial environments
- production line monitoring (indicating the status of various stages in a production line, helping operators manage workflow and efficiency)
- warning and alert systems (e.g. signal safety alerts, malfunctions, or emergency situations) in factories or warehouses

- process control and automation (e.g. to provide real-time feedback on system performance, helping monitor processes and identify issues)

#### KEY FEATURES

- supports up to 5 modules/inputs
- bright, uniform circular signaling
- comprehensive portfolio of options including light and sound modules, mounting bases, and accessories
- easily upgradeable

#### CONTROL

- conventional (via push-in terminal)

# HD

the Design-Tower



The best choice for  
180-degree indoor signaling

Visual and audible LED signal tower with a semi-circular design for wall mounting. Provides optimal signaling with a 180-degree beam angle.

**CUSTOMER BENEFITS**

- compact, pre-configured signal tower with optimum signaling from any view angle
- easily integrates into the environment with three different housing color options

**COMMON APPLICATIONS**

- ideal for access controls in building technology, visualisation of machine status at eye level
- system & filling status and monitoring

**KEY FEATURES**

- supports up to 5 modules/inputs
- bright, uniform directional signaling
- pre-assembled for quick installation
- PLC compatible

**CONTROL**

- conventional (via push-in terminal)

# 7 good reasons to choose Auer Signal

1

Inhouse competence: We develop and manufacture all products in-house.

2

Every product we create is of exceptional quality.

3

Products for every application: Ranging from the premium to the value segment.

4

We develop and produce taylor-made signaling devices.

5

Worldwide use: Our signaling equipment complies with all industry standards.

6

We keep our promises and grow sustainably since 1910.

7

We deliver.

# Auer Signal is one of the world's leading manufacturers of signalling equipment

We are continuously developing new products, inspiring our customers with innovation, foresight, and unwavering quality since 1910. To ensure this remains true, our motto, like our signal devices, is simple: louder & brighter.

Since 1910, we have  
been driven by the will to  
develop technical devices  
that keep getting better

Auer Signal is a fourth generation, owner-managed company with great ambitions. Trust, consistent and reliable quality are important to us as a family company.



# 3D models from Auer Signal

Detailed 3D models are available for all our signaling devices. They can be particularly helpful in the planning and decision-making process when purchasing a signaling device solution.



You can integrate our signaling devices into your design and build software to visualize machines or plants. Using 3D models, you can configure individual signal tower modules, generate parts lists, and incorporate them into your planning process.

All of our 3D models are available for free download on our website, both in the download section and on individual product detail pages.



Download 3D  
models here



# Louder & Brighter since 1910.

## **HEADQUARTERS**

### **Auer Signal GmbH**

Perfektastrasse 102  
1230 Vienna, Austria  
T +43 1 813 82 20  
F +43 1 815 99 51  
office@auersignal.com  
www.auersignal.com

## **USA SUBSIDIARY**

### **Auer Signal Inc.**

1500 District Avenue  
Burlington, MA 01803